

ORDER REFERENCE

PROJECT: UC601 OVERHEAD CABLE DRUM
TYPICAL LAYOUT

PLEASE REFER TO THE PLANNING
GUIDE FOR ADDITIONAL SIZING
AND GATE OPTIONS

OVERHEAD CABLE DRUM
OFFERS A MAXIMUM OF:
6 STOPS
40'-0" OF TRAVEL
15 SQ. FT. CAB SIZE

SPECIFICATIONS

DRIVE: UC601 OVERHEAD CABLE DRUM

CAPACITY: 1000#

LANDINGS: 3

CODE(S): 1 (INCLINATOR LAYOUT DESIGN)

SPEED: AT 38 F.P.M. ±2

SUSPENSION MEANS: (2) STEEL WIRE ROPES 12,100#
BREAKING STRENGTH $\phi 3/8$ - 8 x 19 IWRC

CAR STYLE: 200 STYLE

CAR CONSTRUCTION: 3/4" HARDWOOD VENEER

MANUFACTURED TO MEET:
ASME A17.1 - 2016
IT IS THE RESPONSIBILITY OF THE INSTALLER OF THE UNIT
TO SATISFY ASME, NEC, STATE, AND LOCAL BUILDING CODES

NOTE: ALL MANUFACTURER SUPPLIED CAR AND EQUIPMENT OPTIONS ARE NOTED ON THE CONFIRMING ORDER SHEET.

DISCLAIMER: ONCE DRAWINGS HAVE BEEN APPROVED, SIGNED AND WITHIN 5 DAYS OF PRODUCTION, THE CUSTOMER WILL BEAR ALL RESPONSIBILITY AND LIABILITY OF FINISHED UNIT.



		PROJECT TYPICAL UC601 OHCD				REVISION DATE 11/2017	
		DRAWING VIEW COVER SHEET		DRAWING TEMPLATE NO. 80211292 - REV -		4/2021	
PAGE: 1/7	DRAWN BY: S THOMAS	DATE 3/2017	JOB NO. TYP-OHCD-102	DEALER P.O. NO. -	SCALE NTS	REVISION LEVEL B	

PROJECT:
UC601 OVERHEAD CABLE DRUM
TYPICAL LAYOUT

MANUFACTURED TO MEET:
ASME A17.1 – 2016
IT IS THE RESPONSIBILITY OF THE INSTALLER OF THE UNIT
TO SATISFY ASME, NEC, STATE, AND LOCAL BUILDING CODES

INSTALLED BY:
-

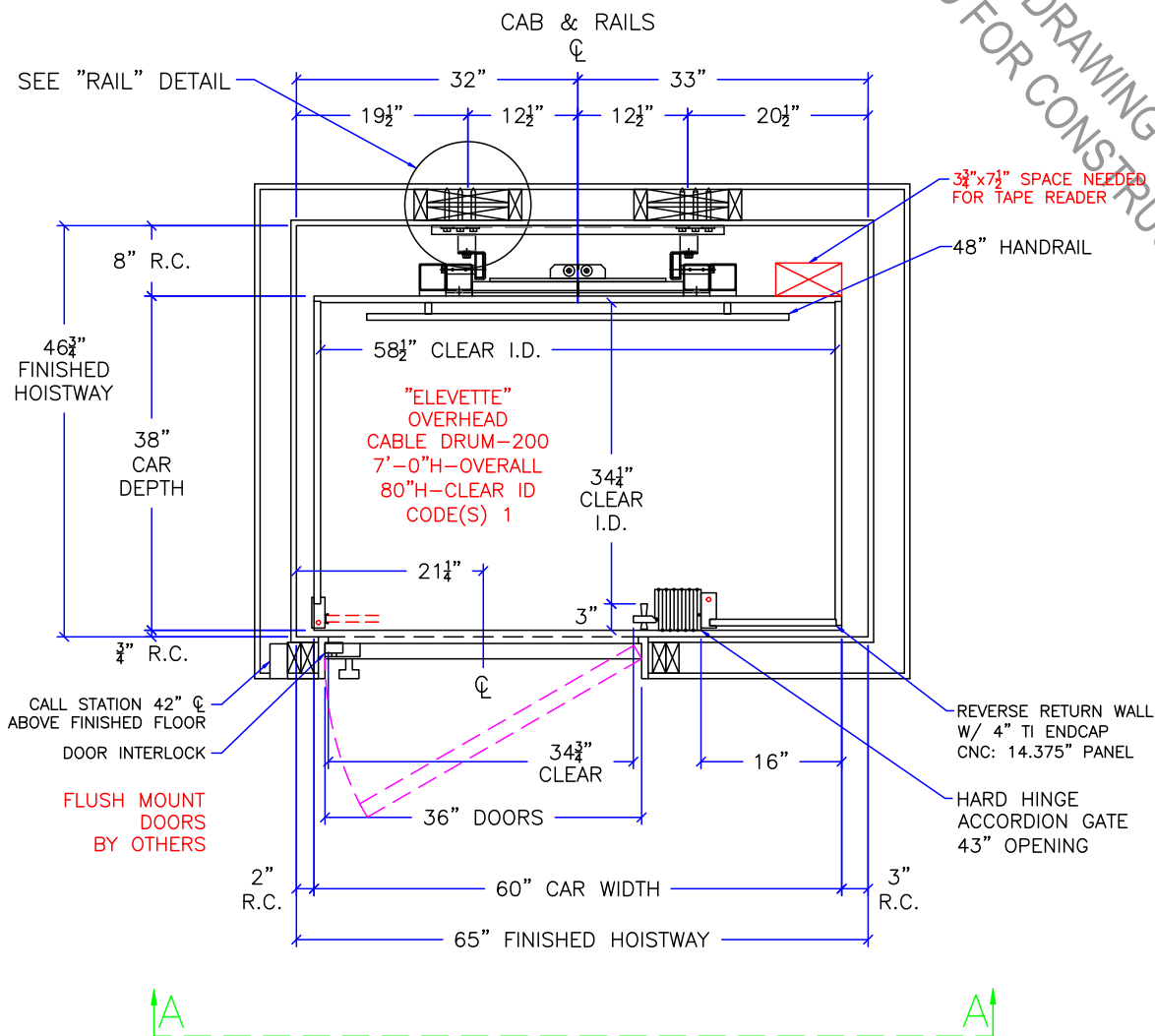

NOTE:
ALL HOISTWAY CONSTRUCTION MUST COMPLY WITH NATIONAL, STATE,
AND LOCAL CODES. HOISTWAY MUST BE PLUMB AND STRAIGHT
FROM TOP TO BOTTOM WITH NO PROJECTIONS INTO THE HOISTWAY.



PROJECT		TYPICAL UC601 OHCD				REVISION DATE	
DRAWING VIEW		HOISTWAY LAYOUT				11/2017	
PAGE: 2/7		DRAWN BY: S THOMAS		DATE: 3/2017		DRAWING TEMPLATE NO. 80211292 - REV -	
JOB NO. TYP-OHCD-102		DEALER P.O. NO. -		SCALE NTS		REVISION LEVEL B	

PROJECT:
UC601 OVERHEAD CABLE DRUM
TYPICAL LAYOUT

MANUFACTURED TO MEET:
ASME A17.1 – 2016
IT IS THE RESPONSIBILITY OF THE INSTALLER OF THE UNIT
TO SATISFY ASME, NEC, STATE, AND LOCAL BUILDING CODES

INSTALLED BY:
-

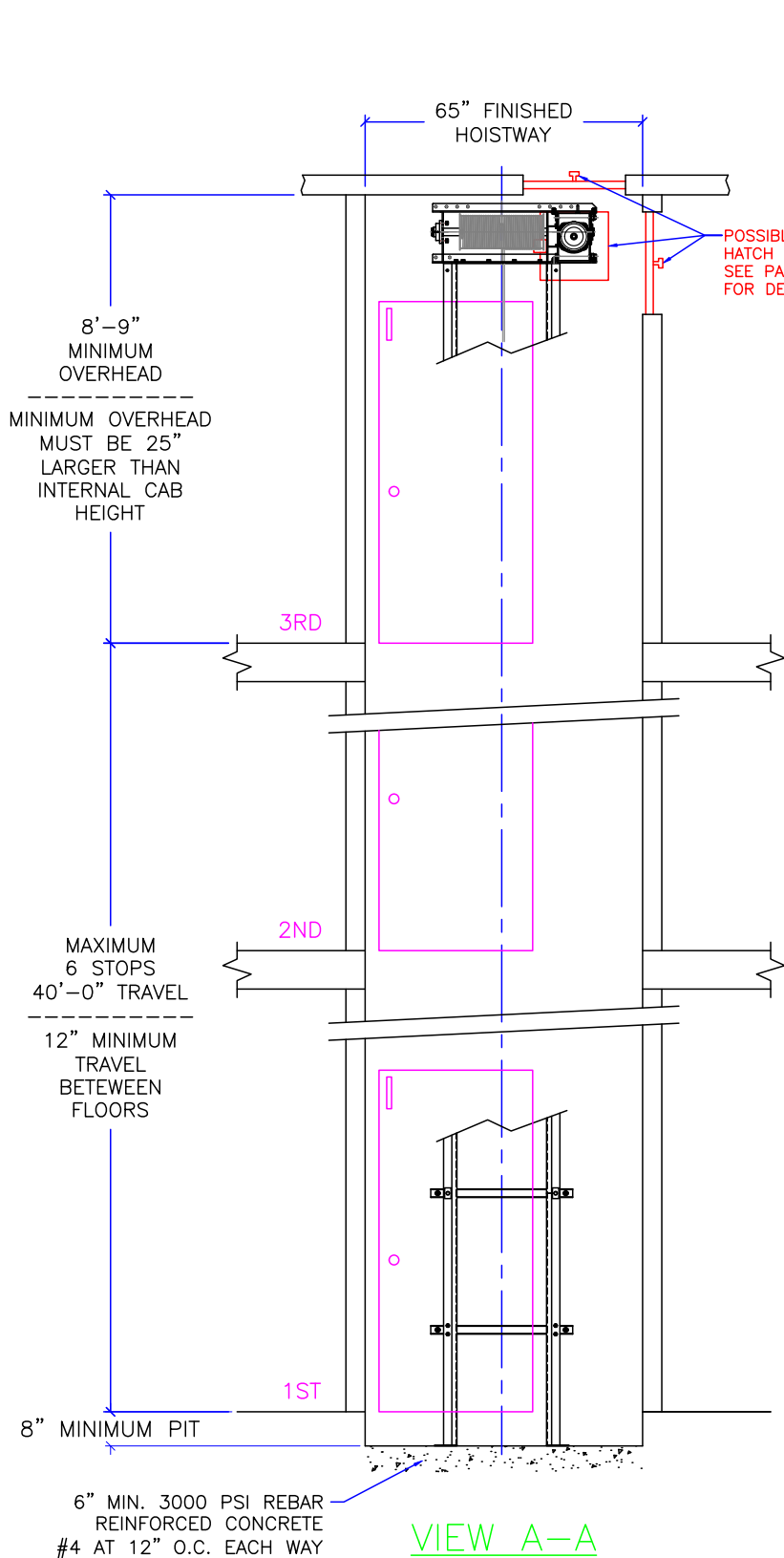

RECOMMENDED BEAM ABOVE HOISTWAY CAPABLE OF SUPPORTING UP TO 1000 LBS. FOR LIFTING POWER UNIT.

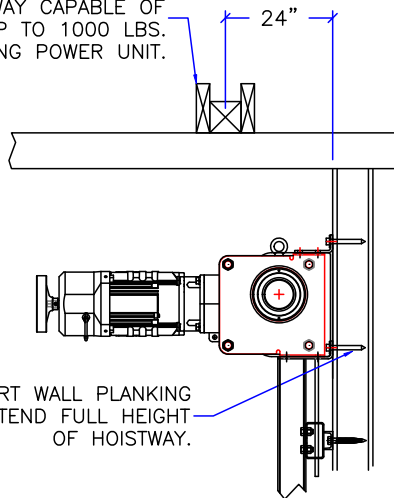

NOTE:
MAX 24" x 24" ACCESS DOOR/HATCH MUST HAVE SPRING-TYPE LOCK AND ELECTRIC SWITCH WIRED INTO CONTROLLER SAFETY CIRCUIT.

NOT TO BE USED FOR CONSTRUCTION
TYPICAL DRAWING

PIT FLOOR REACTIONS
LOAD ON BUFFERS – 3500 LBS
STATIC LOAD – 2400 LBS

PIT FLOOR TO HAVE A SMOOTH TROWEL FINISH FREE OF HOLLOWES OR BUMPS. SURFACE TO BE LEVEL AND FLAT TO WITHIN $\pm \frac{1}{8}$ IN ANY DIRECTION



PROJECT		TYPICAL UC601 OHCD			REVISION DATE	
DRAWING VIEW		SECTION A-A			11/2017	
PAGE: 3/7		DRAWN BY: S THOMAS		DATE: 3/2017		DRAWING TEMPLATE NO. 80211292 – REV –
JOB NO. TYP-OHCD-102		DEALER P.O. NO. –		SCALE NTS		REVISION LEVEL B

PROJECT:
UC601 OVERHEAD CABLE DRUM
TYPICAL LAYOUT

MANUFACTURED TO MEET:
ASME A17.1 – 2016
CONTROL ROOM MUST MEET ALL LOCAL, STATE, AND NATIONAL CODES
INCLUDING ALL APPLICABLE NEC CODE REQUIREMENTS

INSTALLED BY:
—

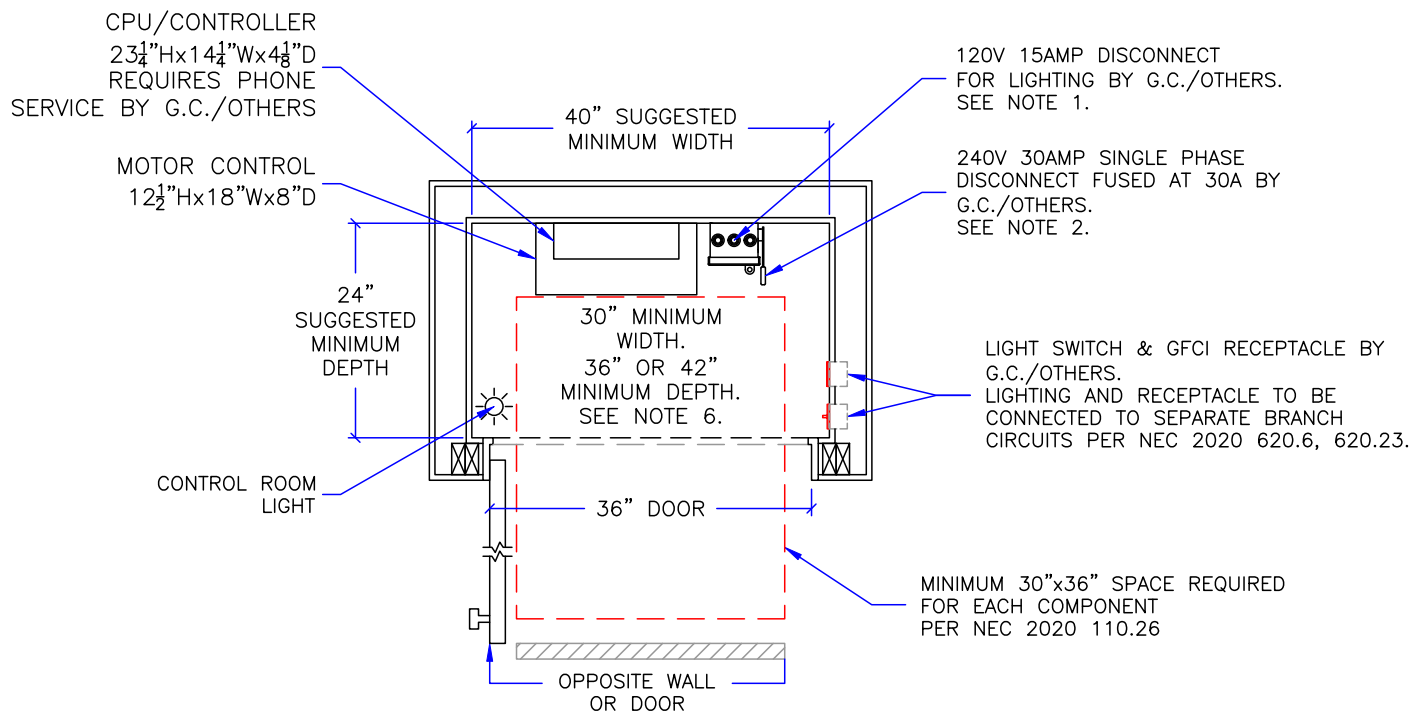

CONTROL ROOM NOTES:

- ELEVATOR CAB LIGHTING RECEPTACLE & ACCESSORIES: 120V 15 AMP EXTERNALLY OPERABLE FUSED LOCKABLE DISCONNECT SWITCH BY G.C./OTHERS PER NEC 2020 620.22, 620.53.
- 240V 30 AMP EXTERNALLY OPERABLE FUSED LOCKABLE DISCONNECT SWITCH BY G.C./OTHERS PER NEC 2020 620.51, 430.110. FUSE TO BE 30A TYPE FRN-R CLASS RK5 OR EQUIVALENT. 30A SUGGESTED BREAKER SIZE FOR POWER TO DISCONNECT.
- IT IS RECOMMENDED THAT THE CPU AND MOTOR CONTROL BE INSTALLED IN THE SAME LOCATION. THE RECOMMENDED WIRING DISTANCE FROM THE CPU TO MOTOR CONTROL UNIT IS 5'. LONGER CABLES UP TO 40' ARE AVAILABLE. CONSULT WITH INCLINATOR WHEN ORDERING.
- CPU AND MOTOR CONTROL SHOULD BE MOUNTED IN A TEMPERATURE CONTROLLED ENVIRONMENT BETWEEN 40°F TO 120°F (4°C – 49°C).
- CPU AND MOTOR CONTROL SHOULD NOT BE EXPOSED TO OUTDOOR ELEMENTS.
- SPACE REQUIREMENTS (INDIVIDUALLY) IN FRONT OF CPU, MOTOR CONTROL, AND DISCONNECTS (REFERENCE NEC 2020 110.26):
 WIDTH: THE WIDTH OF THE CONTROLLERS OR 30", WHICHEVER IS GREATER
 DEPTH: 36" IF THE OPPOSITE WALL OR DOOR IS NOT CONCRETE, BRICK, TILE OR A METALLIC DOOR.
 42" IF THE OPPOSITE WALL OR DOOR IS CONCRETE, BRICK, TILE OR A METALLIC DOOR.
 HEIGHT: MINIMUM 6'-6" FROM GRADE, FLOOR, OR PLATFORM, OR THE HEIGHT OF THE CONTROLLERS, WHICHEVER IS GREATER
- CONTROL ROOM TO HAVE NATURAL/MECHANICAL VENTILATION IF REQUIRED BY STATE OR LOCAL CODES.
- ALL MEANS FOR ACCESS TO EQUIPMENT SHALL BE PROVIDED WITH A LOCK.

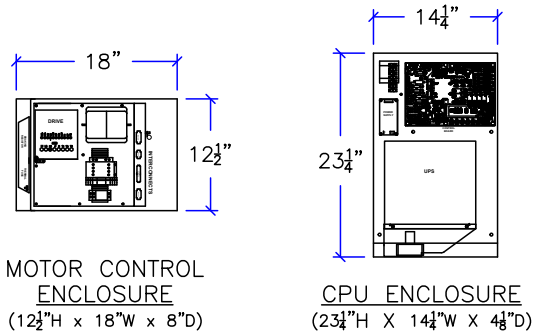

NOTICE TO ELECTRICAL CONTRACTOR:

- ALL ELECTRICAL WIRING MUST BE DONE BY A JOURNEYMAN ELECTRICIAN AND MUST MEET ALL NATIONAL, STATE, AND LOCAL CODES.
- BRING (2) #10 W/GND, ASSUMING 30A BREAKER, FROM RESIDENCE INCOMING POWER PANEL (240V, & GROUND) TO THE CONTROL ROOM.
- BRING (2) #12 W/GND FROM RESIDENCE INCOMING POWER PANEL (120V, NEUTRAL, GROUND) TO THE CONTROL ROOM.
- ALL REQUIRED LOW VOLTAGE WIRING IS SUPPLIED BY INCLINATOR. LOW VOLTAGE WIRING MUST NOT BE EXTENDED OR SPLICED. LONGER CABLES CAN BE PURCHASED FROM INCLINATOR IF NECESSARY.
- AN ANALOG TELEPHONE LINE SHALL BE SUPPLIED TO THE MACHINE ROOM AND SHALL BE CONNECTED TO A 24 HOUR CENTRAL EXCHANGE. THE ELEVATOR PHONE WILL NOT FUNCTION WITH STANDARD DIGITAL/VOIP SERVICE WITHOUT A DIGITAL TO ANALOG CONVERTER.

	PROJECT					REVISION DATE	
	TYPICAL UC601 OHCD					11/2017	
	DRAWING VIEW					4/2021	
CONTROL ROOM REQUIREMENTS					DRAWING TEMPLATE NO.		
					80211292 – REV –		
PAGE:	DRAWN BY:	DATE	JOB NO.	DEALER P.O. NO.	SCALE	REVISION LEVEL	
4/7	S THOMAS	3/2017	TYP-OHCD-102	—	NTS	B	

PROJECT:
UC601 OVERHEAD CABLE DRUM
TYPICAL LAYOUT

MANUFACTURED TO MEET:
ASME A17.1 – 2016
CONTROL SPACE MUST MEET ALL LOCAL, STATE, AND NATIONAL CODES
INCLUDING ALL APPLICABLE NEC CODE REQUIREMENTS

INSTALLED BY:
-

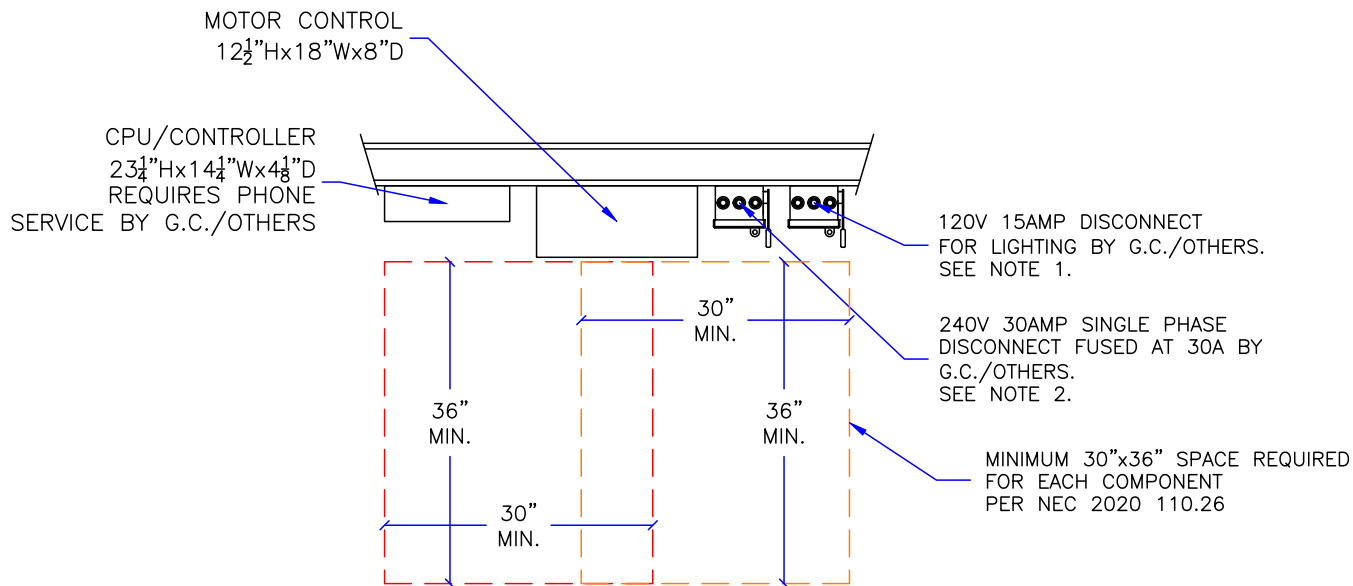

CONTROL SPACE NOTES:

- ELEVATOR CAB LIGHTING RECEPTACLE & ACCESSORIES: 120V 15 AMP EXTERNALLY OPERABLE FUSED LOCKABLE DISCONNECT SWITCH BY G.C./OTHERS PER NEC 2020 620.22, 620.53.
- 240V 30 AMP EXTERNALLY OPERABLE FUSED LOCKABLE DISCONNECT SWITCH BY G.C./OTHERS PER NEC 2020 620.51, 430.110. FUSE TO BE 30A TYPE FRN-R CLASS RK5 OR EQUIVALENT. 30A SUGGESTED BREAKER SIZE FOR POWER TO DISCONNECT.
- IT IS RECOMMENDED THAT THE CPU AND MOTOR CONTROL BE INSTALLED IN THE SAME LOCATION. THE RECOMMENDED WIRING DISTANCE FROM THE CPU TO MOTOR CONTROL UNIT IS 5'. LONGER CABLES UP TO 40' ARE AVAILABLE. CONSULT WITH INCLINATOR WHEN ORDERING.
- CPU AND MOTOR CONTROL SHOULD BE MOUNTED IN A TEMPERATURE CONTROLLED ENVIRONMENT BETWEEN 40°F TO 120°F (4°C – 49°C).
- CPU AND MOTOR CONTROL SHOULD NOT BE EXPOSED TO OUTDOOR ELEMENTS.
- SPACE REQUIREMENTS (INDIVIDUALLY) IN FRONT OF CPU, MOTOR CONTROL, AND DISCONNECTS (REFERENCE NEC 2020 110.26):
 WIDTH: THE WIDTH OF THE CONTROLLERS OR 30", WHICHEVER IS GREATER
 DEPTH: 36" IF THE OPPOSITE WALL OR DOOR IS NOT CONCRETE, BRICK, TILE OR A METALLIC DOOR.
 42" IF THE OPPOSITE WALL OR DOOR IS CONCRETE, BRICK, TILE OR A METALLIC DOOR.
 HEIGHT: MINIMUM 6'-6" FROM GRADE, FLOOR, OR PLATFORM, OR THE HEIGHT OF THE CONTROLLERS, WHICHEVER IS GREATER
- CONTROL SPACE TO HAVE NATURAL/MECHANICAL VENTILATION IF REQUIRED BY STATE OR LOCAL CODES.
- ALL MEANS FOR ACCESS TO EQUIPMENT SHALL BE PROVIDED WITH A LOCK.

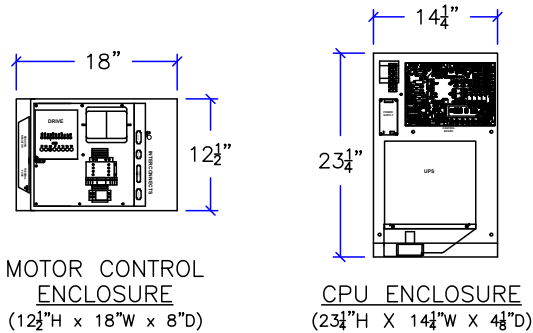

NOTICE TO ELECTRICAL CONTRACTOR:

- ALL ELECTRICAL WIRING MUST BE DONE BY A JOURNEYMAN ELECTRICIAN AND MUST MEET ALL NATIONAL, STATE, AND LOCAL CODES.
- BRING (2) #10 W/GND, ASSUMING 30A BREAKER, FROM RESIDENCE INCOMING POWER PANEL (240V, & GROUND) TO THE CONTROL SPACE.
- BRING (2) #12 W/GND FROM RESIDENCE INCOMING POWER PANEL (120V, NEUTRAL, GROUND) TO THE CONTROL SPACE.
- ALL REQUIRED LOW VOLTAGE WIRING IS SUPPLIED BY INCLINATOR. LOW VOLTAGE WIRING MUST NOT BE EXTENDED OR SPLICED. LONGER CABLES CAN BE PURCHASED FROM INCLINATOR IF NECESSARY.
- AN ANALOG TELEPHONE LINE SHALL BE SUPPLIED TO THE MACHINE ROOM AND SHALL BE CONNECTED TO A 24 HOUR CENTRAL EXCHANGE. THE ELEVATOR PHONE WILL NOT FUNCTION WITH STANDARD DIGITAL/VOIP SERVICE WITHOUT A DIGITAL TO ANALOG CONVERTER.

	PROJECT					REVISION DATE	
	TYPICAL UC601 OHCD					11/2017	
	DRAWING VIEW					4/2021	
CONTROL SPACE REQUIREMENTS					DRAWING TEMPLATE NO.		-
					80211292 – REV –		-
PAGE:	DRAWN BY:	DATE	JOB NO.	DEALER P.O. NO.	SCALE	REVISION LEVEL	
5/7	S THOMAS	3/2017	TYP-OHCD-102	-	NTS	B	

PROJECT:
UC601 OVERHEAD CABLE DRUM
TYPICAL LAYOUT

MANUFACTURED TO MEET:
ASME A17.1 – 2016
IT IS THE RESPONSIBILITY OF THE INSTALLER OF THE UNIT
TO SATISFY ASME, NEC, STATE, AND LOCAL BUILDING CODES

INSTALLED BY:
-

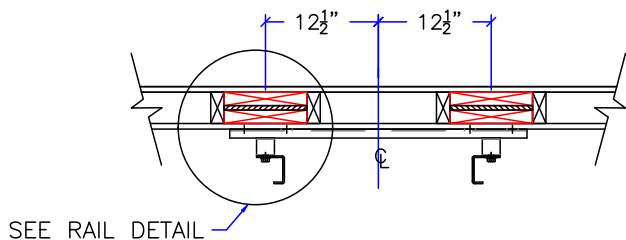

RAIL WALL DETAIL

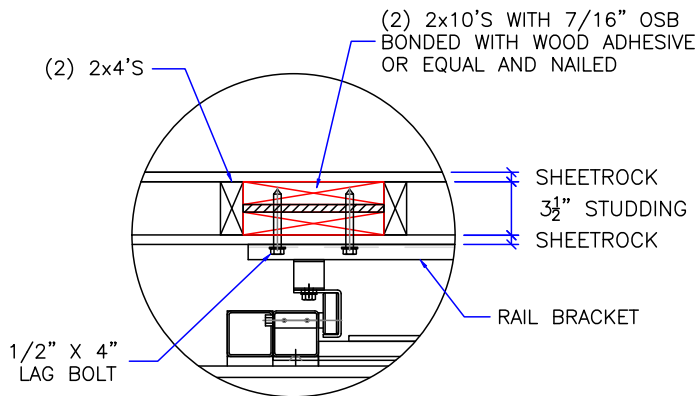

RAIL DETAIL

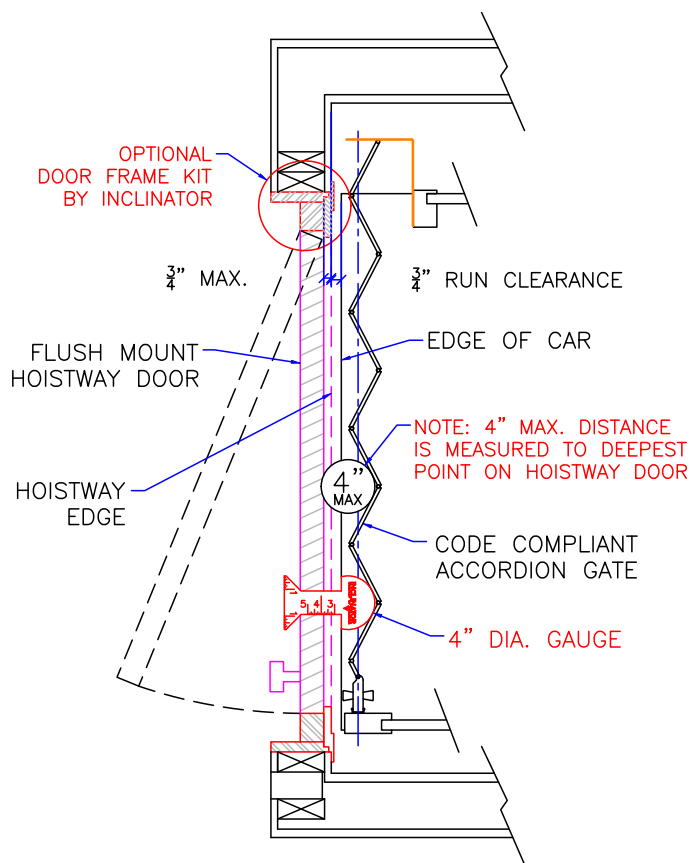

DOOR FRAME DETAILS

REF: ASME 17.1-2016 5.3.1.4.2, 5.3.1.7.2, & 5.3.1.8.3

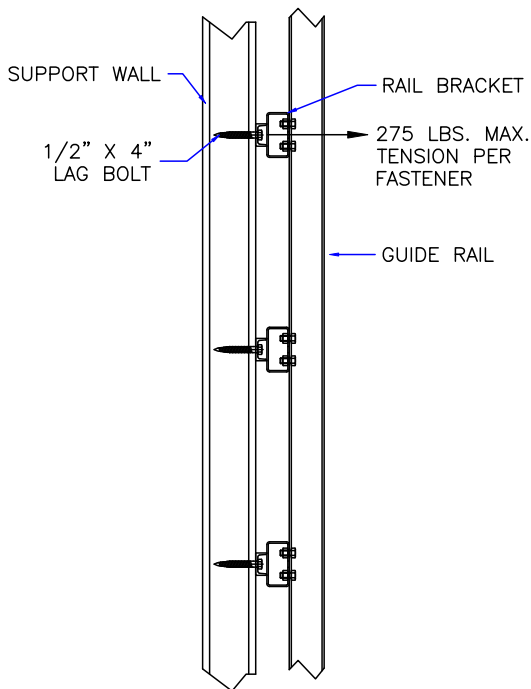

SUPPORT BRACKET PULL OUT



PROJECT		TYPICAL UC601 OHCD			REVISION DATE	
DRAWING VIEW		DETAILS, DATA, CODES			11/2017	
PAGE: 6/7		DRAWN BY: S THOMAS		DATE: 3/2017		4/2021
JOB NO. TYP-OHCD-102		DEALER P.O. NO. -		SCALE NTS		REVISION LEVEL B

PROJECT:
UC601 OVERHEAD CABLE DRUM
TYPICAL LAYOUT

MANUFACTURED TO MEET:
ASME A17.1 – 2016
IT IS THE RESPONSIBILITY OF THE INSTALLER OF THE UNIT
TO SATISFY ASME, NEC, STATE, AND LOCAL BUILDING CODES

INSTALLED BY:
-

MAX 24" x 24" ACCESS
DOOR/HATCH MUST
HAVE SPRING-TYPE
LOCK AND ELECTRIC
SWITCH WIRED INTO
CONTROLLER SAFETY
CIRCUIT.

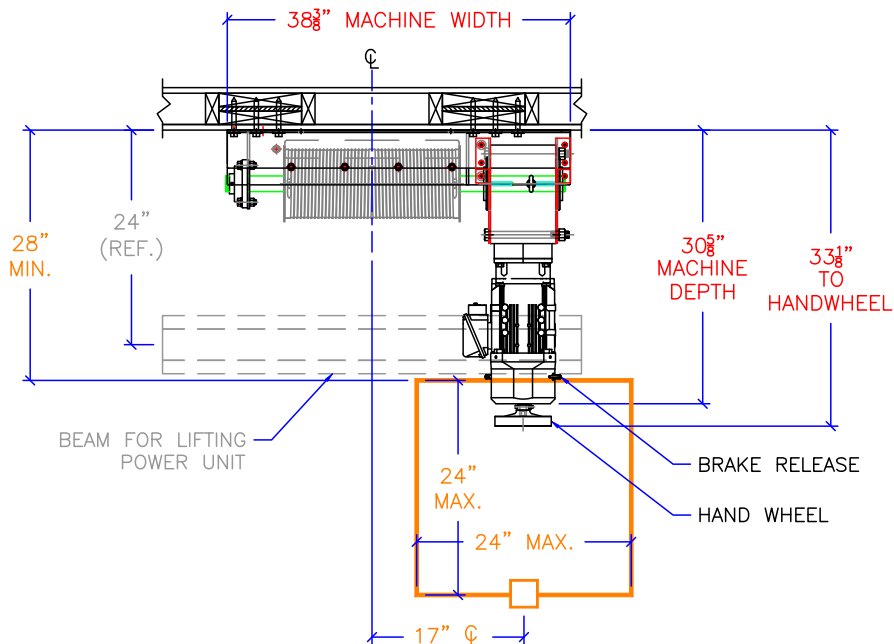

ACCESS DOOR/HATCH
SHOULD BE POSITIONED
TO PROVIDE PROPER
ACCESS TO THE BRAKE
RELEASE AND HANDWHEEL.

ACCESS DOOR/HATCH (CEILING)

ACCESS DOOR/HATCH
SHOULD BE POSITIONED
TO PROVIDE PROPER
ACCESS TO THE BRAKE
RELEASE AND HANDWHEEL.

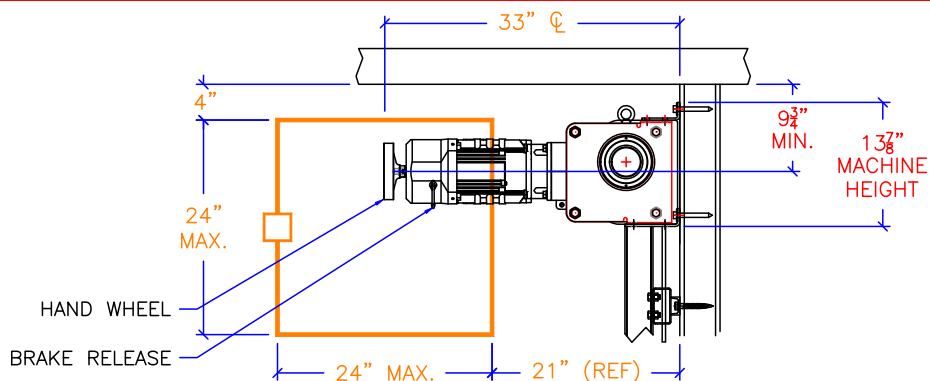

ACCESS DOOR/HATCH (EAST WALL)

ACCESS DOOR/HATCH
SHOULD BE POSITIONED
TO PROVIDE PROPER
ACCESS TO THE BRAKE
RELEASE AND HANDWHEEL.

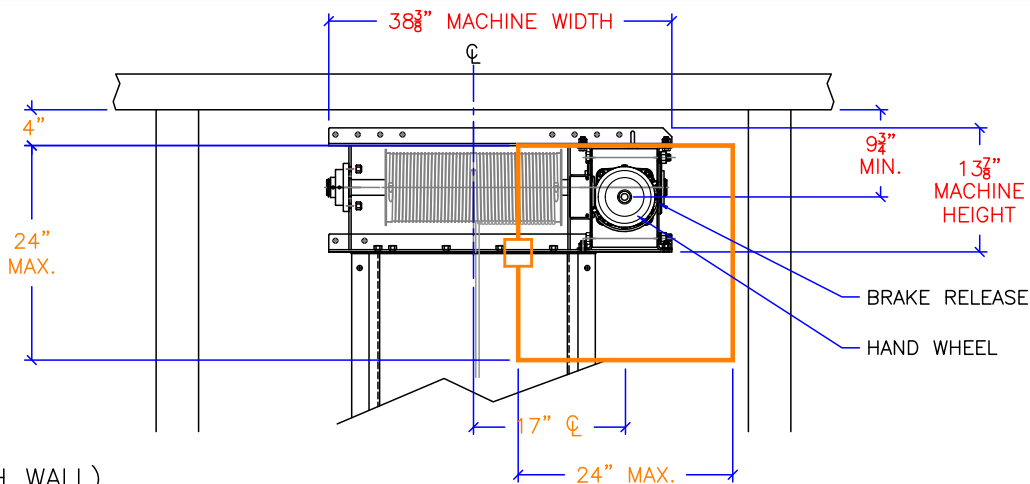

ACCESS DOOR/HATCH (SOUTH WALL)



PROJECT				TYPICAL UC601 OHCD		REVISION DATE	
DRAWING VIEW				POSSIBLE ACCESS PANEL LOCATIONS		DRAWING TEMPLATE NO.	
PAGE:				DRAWN BY:		DATE	
7/7				S THOMAS		3/2017	
JOB NO.				DEALER P.O. NO.		SCALE	
TYP-OHCD-102				-		NTS	
REVISION DATE				11/2017		4/2021	
REVISION LEVEL				-		B	

PROJECT:
UC601 OVERHEAD CABLE DRUM
TYPICAL LAYOUT

MANUFACTURED TO MEET:
ASME A17.1 – 2016
IT IS THE RESPONSIBILITY OF THE INSTALLER OF THE UNIT
TO SATISFY ASME, NEC, STATE, AND LOCAL BUILDING CODES

INSTALLED BY:
-

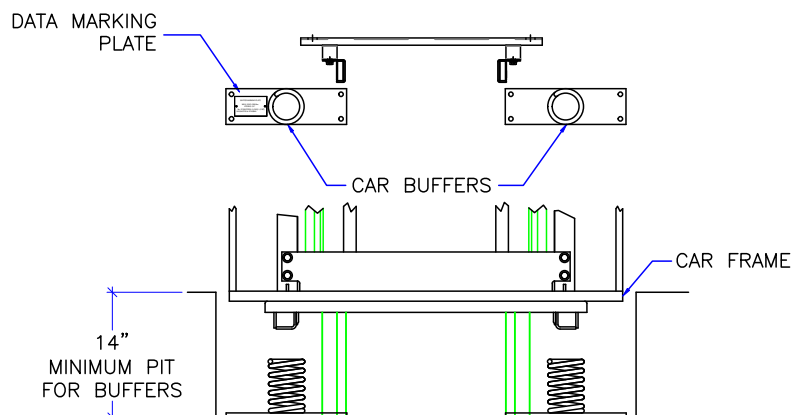

SPRING BUFFERS
SPRING WILL DEPRESS
1" AT 373 LBS.
(MANUFACTURERS
SPECIFICATION)

BUFFER OPTION

MANDATORY WHEN OCCUPIABLE SPACE BELOW ELEVATOR

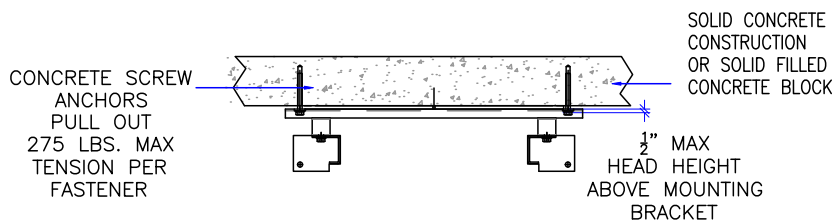

SOLID CONCRETE

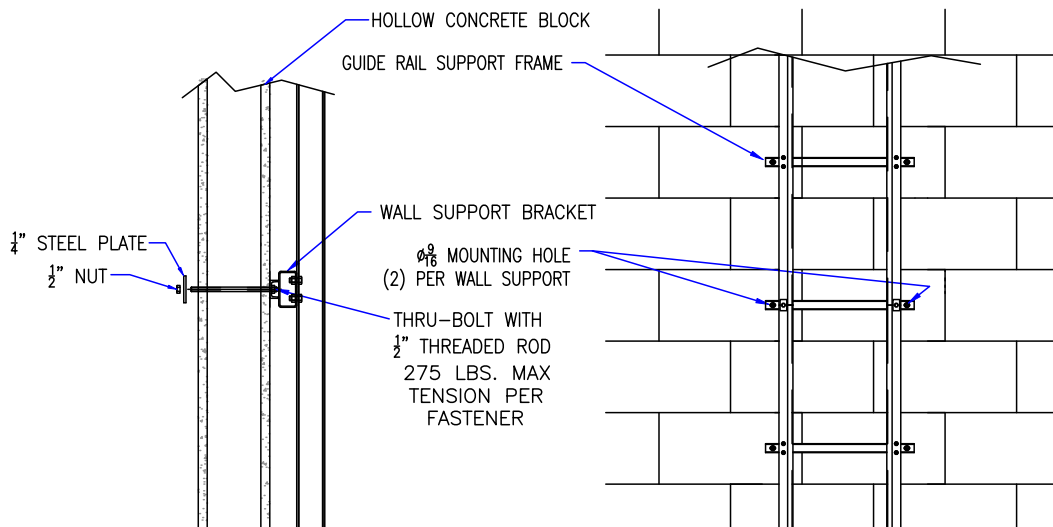

HOLLOW CONCRETE



PROJECT		TYPICAL UC601 OHCD			REVISION DATE		
DRAWING VIEW		OPTIONS			11/2017		
PAGE: AUX1		DRAWN BY: S THOMAS		DATE: 3/2017		DRAWING TEMPLATE NO. 80211292 - REV -	
JOB NO. TYP-OHCD-102		DEALER P.O. NO. -		SCALE NTS		REVISION LEVEL B	
						4/2021	

PROJECT:
UC601 OVERHEAD CABLE DRUM
TYPICAL LAYOUT

MANUFACTURED TO MEET:
ASME A17.1 – 2016
IT IS THE RESPONSIBILITY OF THE INSTALLER OF THE UNIT
TO SATISFY ASME, NEC, STATE, AND LOCAL BUILDING CODES

INSTALLED BY:
-

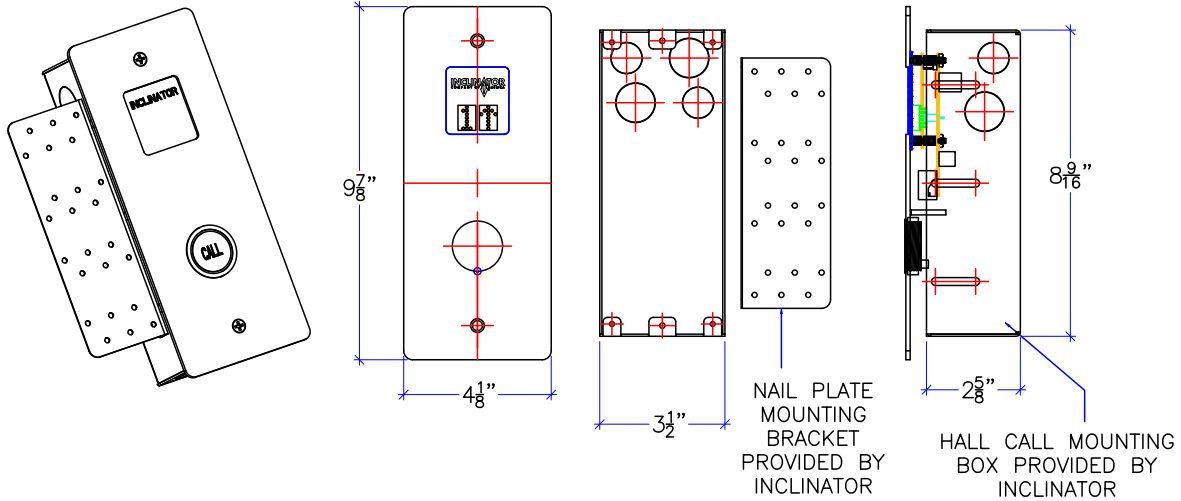

FLUSH MOUNT HALL CALL STATION

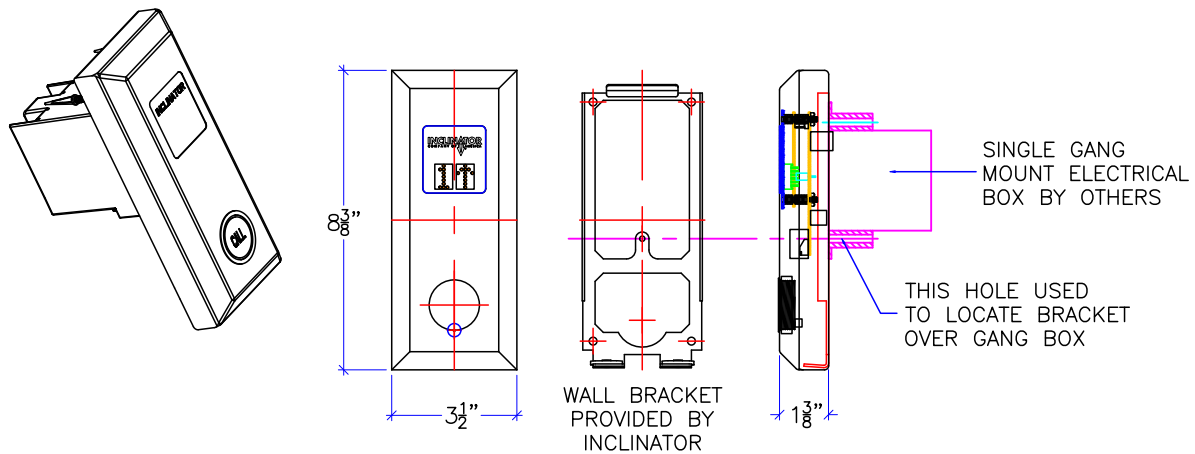

RAISED MOUNT HALL CALL STATION



PROJECT		TYPICAL UC601 OHCD				REVISION DATE	
DRAWING VIEW		CALL STATIONS				11/2017	
PAGE: AUX2		DRAWN BY: S THOMAS		DATE: 3/2017		DRAWING TEMPLATE NO. 80211292 – REV –	
JOB NO. TYP-OHCD-102		DEALER P.O. NO. –		SCALE NTS		REVISION LEVEL B	

PROJECT:
UC601 OVERHEAD CABLE DRUM
TYPICAL LAYOUT

MANUFACTURED TO MEET:
ASME A17.1 – 2016
IT IS THE RESPONSIBILITY OF THE INSTALLER OF THE UNIT
TO SATISFY ASME, NEC, STATE, AND LOCAL BUILDING CODES

INSTALLED BY:
-

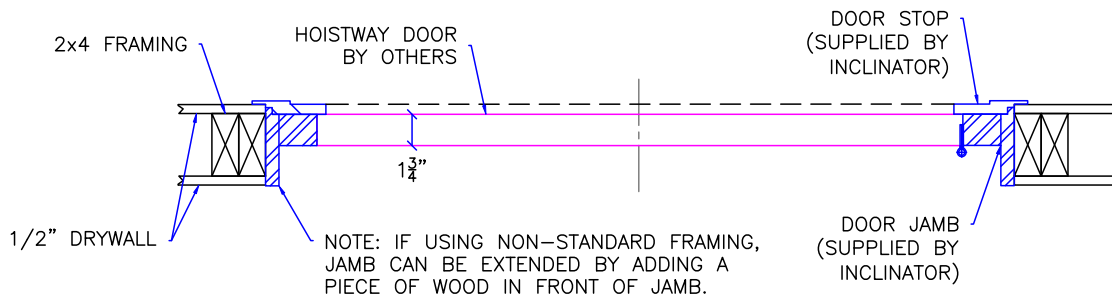

DOOR FRAME DETAIL
STANDARD 2x4 CONSTRUCTION WITH
1/2" DRYWALL (INSIDE & OUTSIDE OF HOISTWAY)

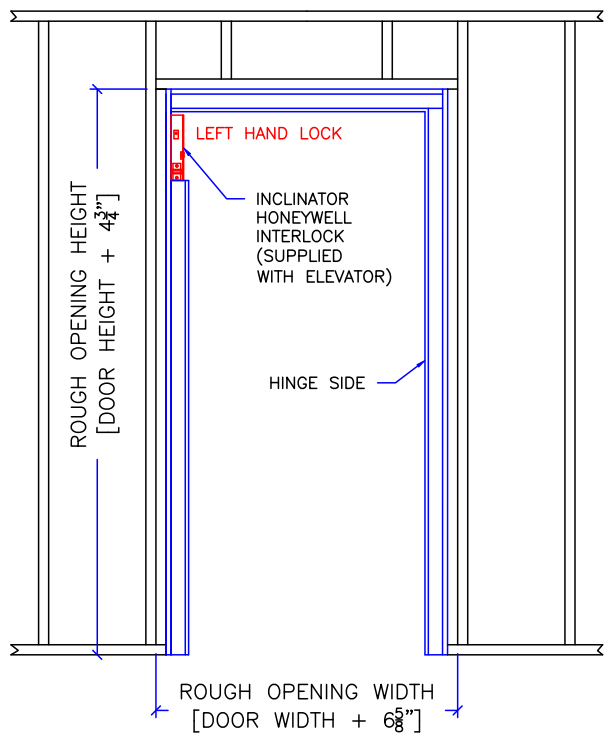

HALLWAY VIEW

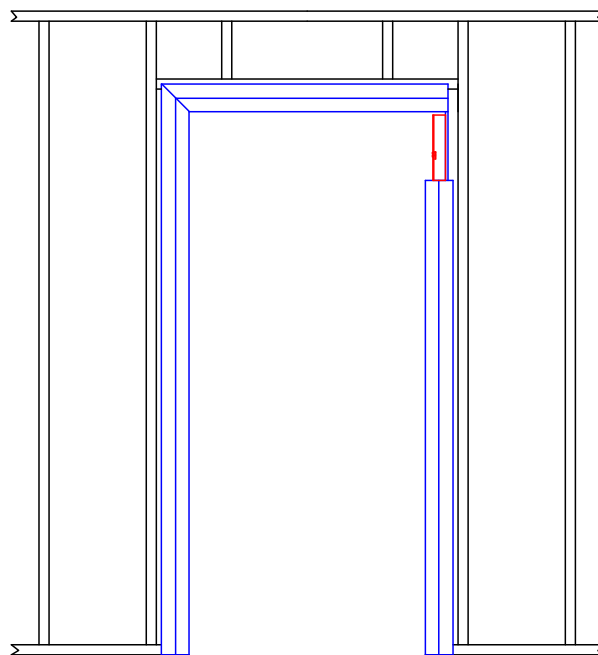

HOISTWAY VIEW



PROJECT		TYPICAL UC601 OHCD			REVISION DATE		
DRAWING VIEW		FLUSH MOUNT DOOR FRAME KIT			11/2017		
PAGE: AUX3		DRAWN BY: S THOMAS		DATE: 3/2017		DRAWING TEMPLATE NO. 80211292 - REV -	
JOB NO. TYP-OHCD-102		DEALER P.O. NO. -		SCALE NTS		REVISION LEVEL B	